

Versiune	Insula - 800 m ³ /h
Design	Vittore Niolu Silence - NRS
Technology	Scotch brite stainless steel (AISI 304) Sticlă Tehnologie NRS pentru liniște în bucătărie Iluminare difuză pe întreaga suprafață
Control	Panou de control electronic Dialogue system cu mod automat Telecomandă (opțional)
Modul	
Raft	Raft de sticlă opțional
Iluminat	
Filters	Filtru de grăsime din metal, detașabil și lavabil Filtru Regenerable Carbon.Zeo Microtech (opțional)
Dimensions	180 cm 52 cm 60 cm
Notes	Availability Carbon.Zeo filter KACL.1039 for hoods produced from Sept. 2024
Tensiune/frecvență	350 W 220-240V 50-60Hz
Plug	Shuko
Motor	800 m ³ /h 610 m ³ /h I.E.C.61591 46 dB (A)re1pW I.E.C. 60704-2-13 C
Net Weight	38 kg 32 kg 0.42 m ³ L 1070 x H 452 x P 870 mm

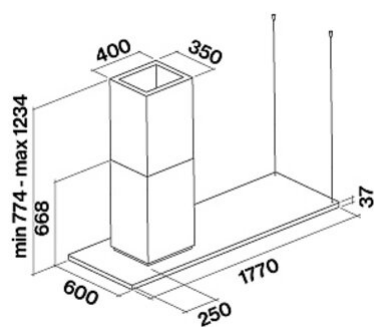



Accessorii optionale

Code	Description
KACL.129	Glass kit 180 cm
KACL.1039	Filtru Regenerabil Carbon.Zeo Microtech
KACL.400	Tubulatura NRS
105080053	Telecomanda
KACL.815	Șervețel de protecție pentru suprafețe din oțel inoxidabil (cutie 10 buc.)

Viteza motorului	1	2	3	4
	37	41	46	54,5
	220	290	375	610
	390	440	490	510
	130	150	178	224
leșire aer	150	150	150	150

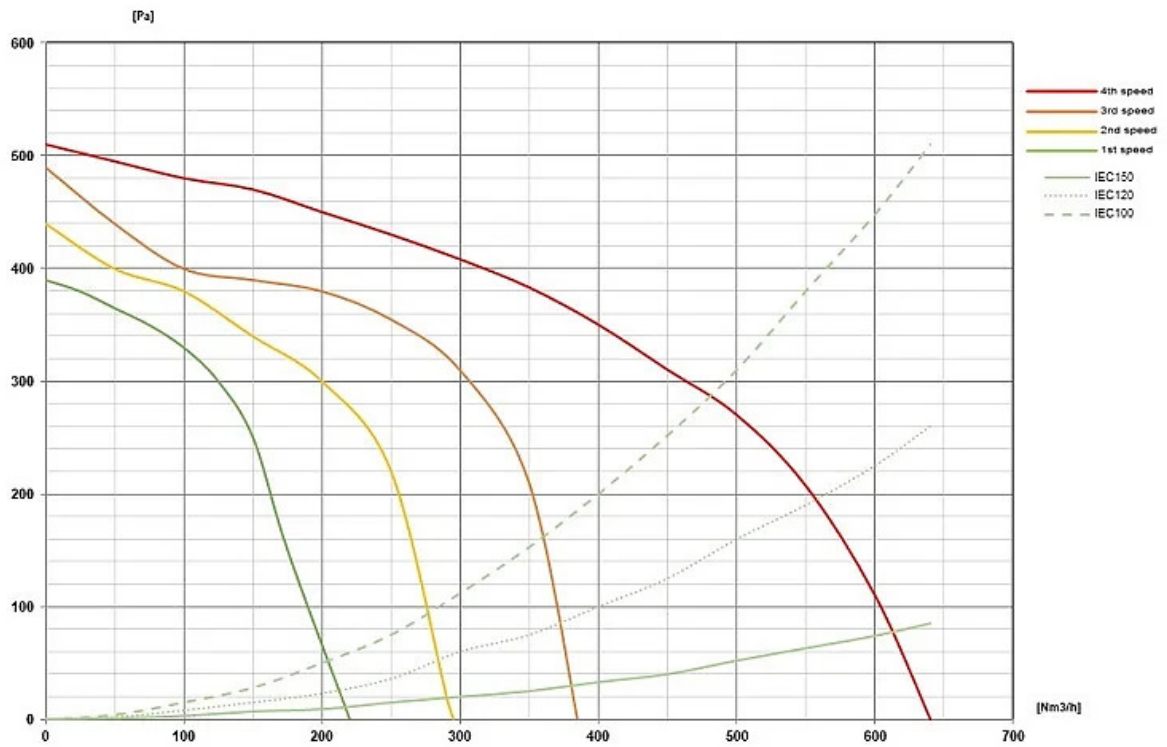

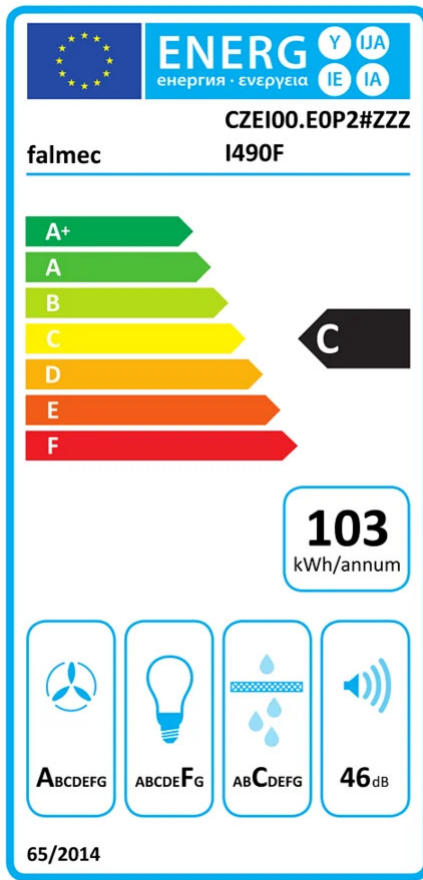

PF		
S	Vittore Niolu	
M	Insula - 800 m ³ /h	
AEC	103.30	kWh/a
EEC	C	
FDE	28.90	
FDEC	A	
LE	6.80	
LEC	F	
GFE	76	
GFEC	C	
Qmin	220	m ³ /h
Qmax	375	m ³ /h
Qboost	610	m ³ /h
SPEmin	37	dBa
SPEmax	46	dBa
SPEboost	54	dBa
PO		
PS	0.48	W
PI		
F	1.00	
EEL	80.00	
Qbep	369	m ³ /h
Pbep	369	Pa
Qboost	610	m ³ /h
Wbep	131	W
WL	76.00	W
Emiddle	519	lux
Lwa-SPEmax	46	dBa

PF_Scheda prodotto conforme a 65/2014 S_Supplier name / M_Model identification / AEC_Annual Energy Consumption (AEC hood) / EEC_Energy Efficiency class / FDE_Fluid Dynamic Efficiency (FDE hood) / FDEC_Fluid Dynamic Efficiency class / LE_Lighting Efficiency (LE hood) / LEC_Lighting Efficiency class / GFE_Grease Filtering Efficiency / GFEC_Grease Filtering Efficiency class / Qmin_Air flow (in m³/h) at min speed in normal use / Qmax_Air flow (in m³/h) at max speed in normal use / Qboost_Air flow (in m³/h) at intensive or boost setting (max air-flow) / SPEmin_Airborne acoustical A-weighted sound power emissions (in dB) at min speed in normal use / SPEmax_Airborne acoustical A-weighted sound power emissions at max speed in normal use / SPEboost_Airborne acoustical A-weighted sound power emissions (in dB) at intensive or boost setting / P0_Power consumption in off mode (Po) / Ps_Power consumption in stand by mode (Ps).

PI_Additional information according to 66/2014 Calculation methods: EN 61591:2020 F_Time increase factor / EEL_Energy Efficiency Index / Qbep_Measured air flow rate at best efficiency point / Pbep_Measured air pressure at best efficiency point / Qboost_Maximum air flow / Wbep_Measured electric power input at best efficiency point / WL_Nominal power of the lighting system / Emiddle_Average illumination of the lighting system on the cooking surface / Lwa=SPEmax_Sound pressure level at the highest speed.