

Versiune	De plafon -120 cm - sticlă
Design	Saggia - Sommella Design Sticlă Oțel vopsit alb Aspirație perimetrală Iluminat perimetral cu LED-uri Posibilitatea de a picta panoul
Control	Panou de control electronic Telecomandă inclusă Dialogue system cu mod automat
Modul	
Iluminat	LED (4000 K)
Filters	Filtru de grăsime din metal, detașabil și lavabil Filtru combinat Carbon.Zeo, regenerabil (opțional)
Motor	Motor vândut separat
Dimensions	120 cm 150 cm 150 cm
Notes	
Tensiune/frecvență	90 W 220-240V 50-60Hz
Motor	Motor de acoperis 950 m3/h Motor subțire 800 m3/h Remote under-roof 1100 m3/h Brushless Motor de acoperis 1300 m3/h Motor de exterior 1000 m3/h Motor de exterior 1500 m3/h 830 m ³ /h I.E.C.61591 64 dB (A)re1pW I.E.C. 60704-2-13 C
Net Weight	52.2 kg 45.2 kg 0.37 m3 L 1395 x H 312 x P 865 mm

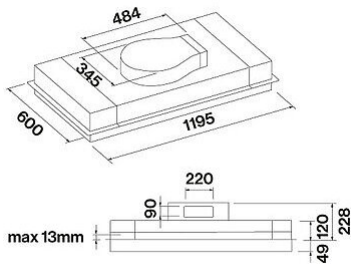

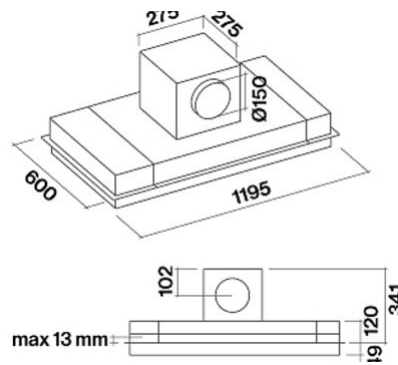

Hood and motor dimensions



Hood and motor dimensions

Accessorii optionale

Code	Description
KACL.782#49F	Motor subțire 800 m3/h
KACL.789	Junction for ceiling hoods
KACL.798#41F	Motor de acoperis 950 m3/h
KACL.786#41F	Motor de exterior 1000 m3/h
KACL.796#4AF	Motor de exterior 1500 m3/h
KACL.797#4AF	Motor de acoperis 1300 m3/h
KACL.939#BF	Kit de filtrare pentru verisunea recirculare in plafon (doar pentru Motorul Slim)
KACL.928	Replacement Carbon.Zeo filter for horizontal outlet
KACL.953#BF	Carbon.Zeo vertical outlet ceiling filter unit kit
KACL.931	Filter replacement Carbon.Zeo for vertical outlet and under base kit h100 mm
KACL.398	Ø150 - Flange
KACL.396	Flanșă - Ø200

MOTOR DE ACOPERIS 950 M3/H

CARATTERISTICHE TECNICHE MOTORE

	1	2	3	4
	50	57	64	68
	360	480	630	830
	480	520	560	580
	190	220	250	270
	150	150	150	150

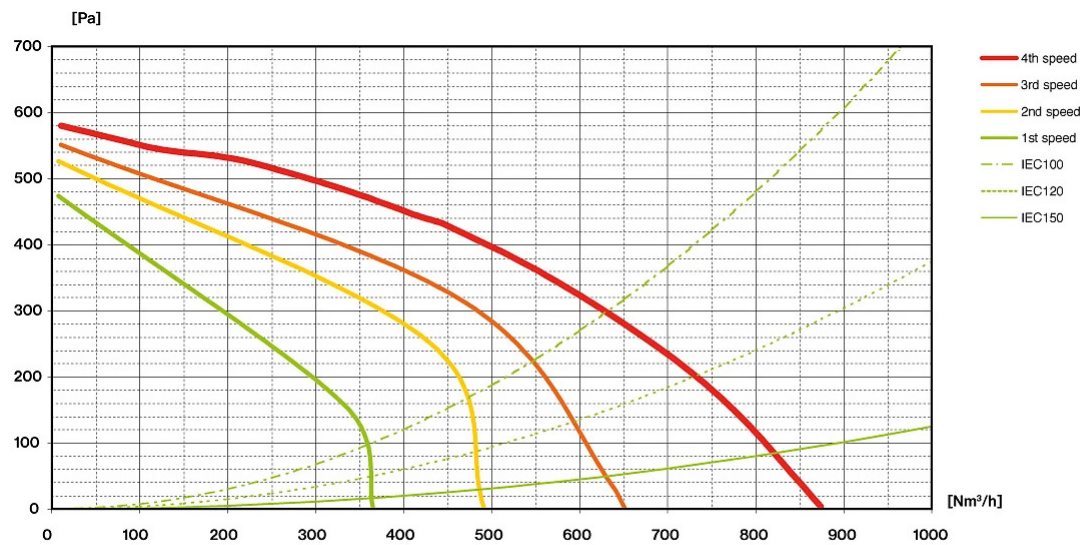

MOTOR SUBȚIRE 800 M3/H

CARATTERISTICHE TECNICHE MOTORE

	1	2	3	4
	52	58	63	66
	285	340	470	550
	400	480	500	600
	100	110	120	150
	220x90	220x90	220x90	220x90

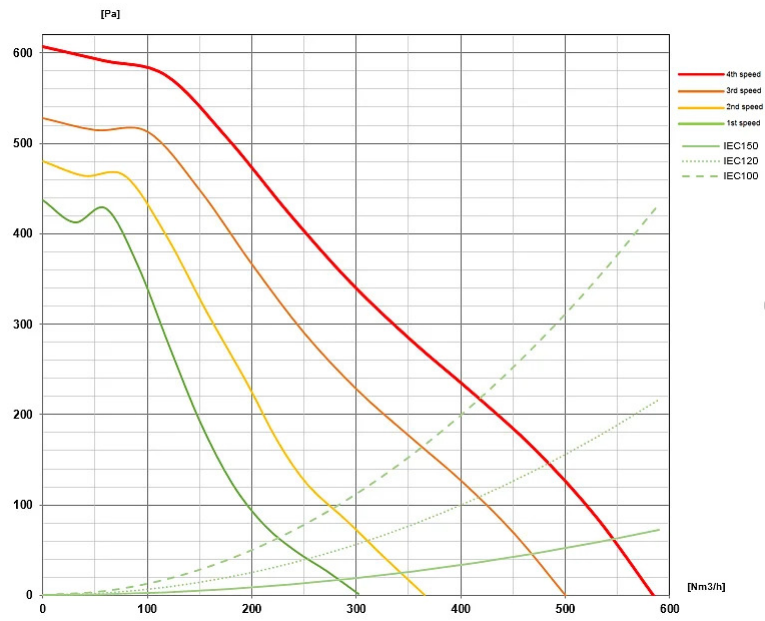

MOTOR DE ACOPERIS 950 M3/H

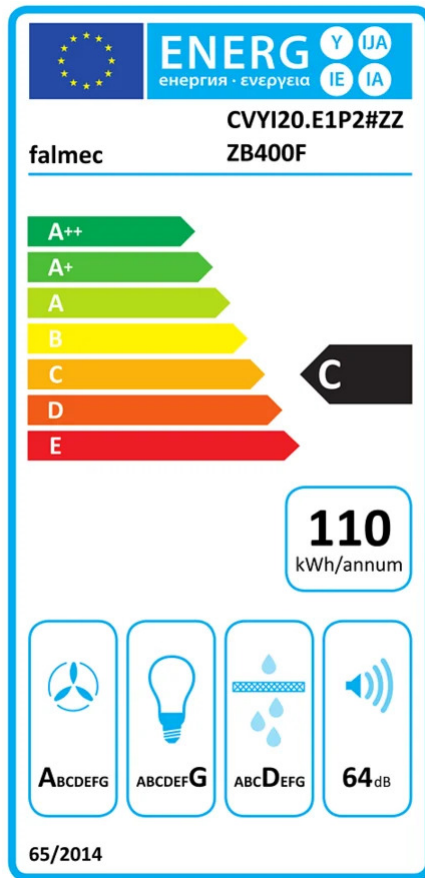

PF		
S	Saggia - Sommella	
M	Motor de acoperis 950 m3/h	
AEC	110.20	kWh/a
EEC	C	
FDE	29.50	
FDEC	A	
LE	4.00	
LEC	G	
GFE	65.1	
GFEC	D	
Qmin	360	m ³ /h
Qmax	630	m ³ /h
Qboost	830	m ³ /h
SPEmin	50	dBa
SPEmax	64	dBa
SPEboost	68	dBa
PO		
PS	0.48	W
PI		
F	0.90	
EEl	72.10	
Qbep	441	m ³ /h
Pbep	434	Pa
Qboost	830	m ³ /h
Wbep	180	W
WL	70.00	W
Emiddle	277	lux
Lwa-SPEmax	64	dBa

MOTOR SUBȚIRE 800 M3/H

PF		
S	Motor subțire 800 m3/h	
M	Motor subțire 800 m3/h	
AEC	97.3	kWh/a
EEC	C	
FDE	24.3	
FDEC	B	
LE	4	
LEC	G	
GFE	65.1	
GFEC	D	
Qmin	285	m ³ /h
Qmax	470	m ³ /h
Qboost	550	m ³ /h
SPEmin	52	dBa
SPEmax	63	dBa
SPEboost	66	dBa
PO	0	W
PS	0.48	W
PI		
F	1.1	
EEL	83.1	
Qbep	337	m ³ /h
Pbep	298	Pa
Qboost	550	m ³ /h
Wbep	115	W
WL	70	W
Emiddle	277	lux
Lwa-SPEmax		dBa

PF_Scheda prodotto conforme a 65/2014 S_Supplier name / M_Model identification / AEC_Annual Energy Consumption (AEC hood) / EEC_Energy Efficiency class / FDE_Fluid Dynamic Efficiency (FDE hood) / FDEC_Fluid Dynamic Efficiency class / LE_Lighting Efficiency (LE hood) / LEC_Lighting Efficiency class / GFE_Grease Filtering Efficiency / GFEC_Grease Filtering Efficiency class / Qmin_Air flow (in m³/h) at min speed in normal use / Qmax_Air flow (in m³/h) at max speed in normal use / Qboost_Air flow (in m³/h) at intensive or boost setting (max air-flow) / SPEmin_Airborne acoustical A-weighted sound power emissions (in dB) at min speed in normal use / SPEmax_Airborne acoustical A-weighted sound power emissions at max speed in normal use / SPEboost_Airborne acoustical A-weighted sound power emissions (in dB) at intensive or boost setting / P0_Power consumption in off mode (Po) / Ps_Power consumption in stand by mode (Ps).

PI_Additional information according to 66/2014 Calculation methods: EN 61591:2020 F_Time increase factor / EEL_Energy Efficiency Index / Qbep_Measured air flow rate at best efficiency point / Pbep_Measured air pressure at best efficiency point / Qboost_Maximum air flow / Wbep_Measured electric power input at best efficiency point / WL_Nominal power of the lighting system / Emiddle_Average illumination of the lighting system on the cooking surface / Lwa=SPEmax_Sound pressure level at the highest speed.