

Versiune	De plafon - 90 cm - Inox
Design	Falmec Lab Design
	Scotch brite stainless steel (AISI 304) Aspirație perimetrală
Control	Panou de control electronic Telecomandă inclusă Dialogue system cu mod automat
Modul	
Filters	Filtru de grăsime din metal, detașabil și lavabil Filtru combinat Carbon.Zeo, regenerabil (opțional) Filtru Regenerabil Carbon.Zeo Microtech (opțional)
Motor	Motor vândut separat
Dimensions	90 cm 150 cm 150 cm
Notes	Dimensiune decupaj: 505x940 mm
	0 W
Tensiune/frecvență	220-240V 50-60Hz
Plug	Shuko
Motor	Motor subțire 800 m ³ /h Motor de acoperis 950 m ³ /h 695 m ³ /h I.E.C.61591 62 dB (A)re1pW I.E.C. 60704-2-13 B
Net Weight	26 kg 22.8 kg 0.17 m ³ L 1120 x H 222 x P 670 mm

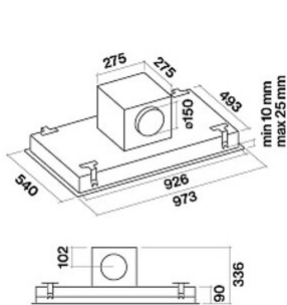

Nube 90 - under roof motor

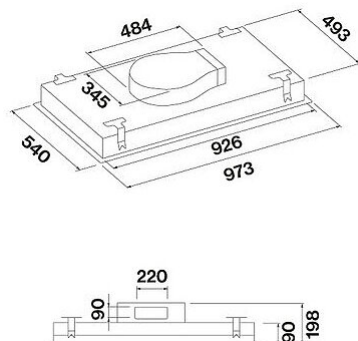

Nube 90 - slim motor

Accessorii optionale

Code	Description
KACL.782#49F	Motor subțire 800 m3/h
KACL.798#41F	Motor de acoperis 950 m3/h
KACL.786#41F	Motor de exterior 1000 m3/h
KACL.796#4AF	Motor de exterior 1500 m3/h
KACL.797#4AF	Motor de acoperis 1300 m3/h
KACL.939#BF	Kit de filtrare pentru verisunea recirculare in plafon (doar pentru Motorul Slim)
KACL.1049	Carbon.Zeo Microtech filtru regenerabil pentru hote de plafon de până la 100 cm
KACL.928	Replacement Carbon.Zeo filter for horizontal outlet
KACL.953#BF	Carbon.Zeo vertical outlet ceiling filter unit kit
KACL.931	Filter replacement Carbon.Zeo for vertical outlet and under base kit h100 mm
KACL.789	Junction for ceiling hoods
KACL.398	Ø150 - Flange
KACL.396	Flanșă - Ø200

MOTOR SUBTIRE 800 M3/H

CARATTERISTICHE TECNICHE MOTORE

	1	2	3	4
	52	58	63	66
	245	350	470	540
	400	480	530	600
	100	110	120	150
	220x90	220x90	220x90	220x90

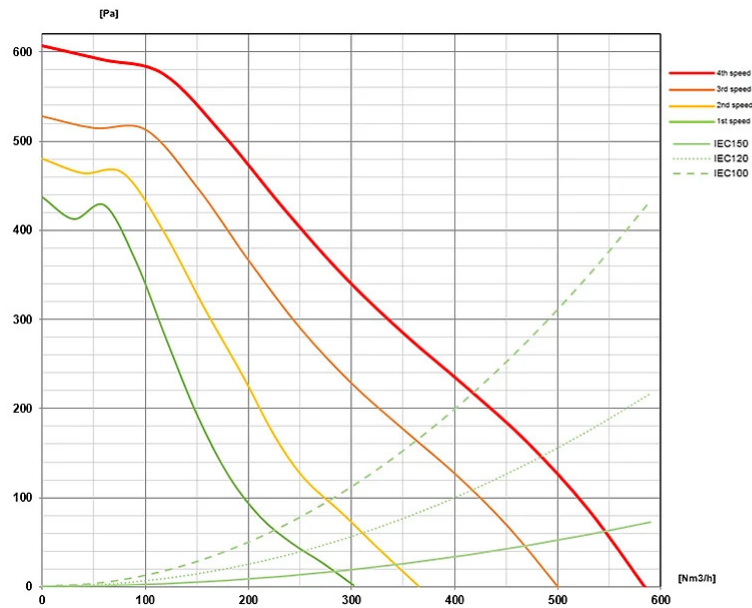

MOTOR DE ACOPERIS 950 M3/H

CARATTERISTICHE TECNICHE MOTORE

	1	2	3	4
	48	56	62	66
	365	480	600	695
	510	520	560	590
	190	220	250	270
	150	150	150	150

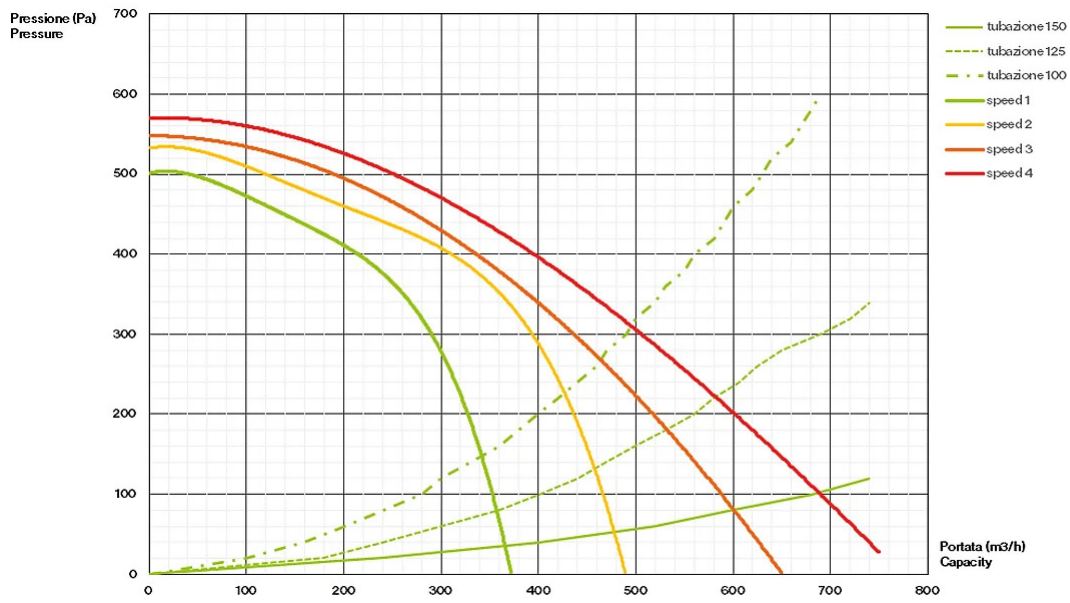

MOTOR DE ACOPERIS 950 M3/H

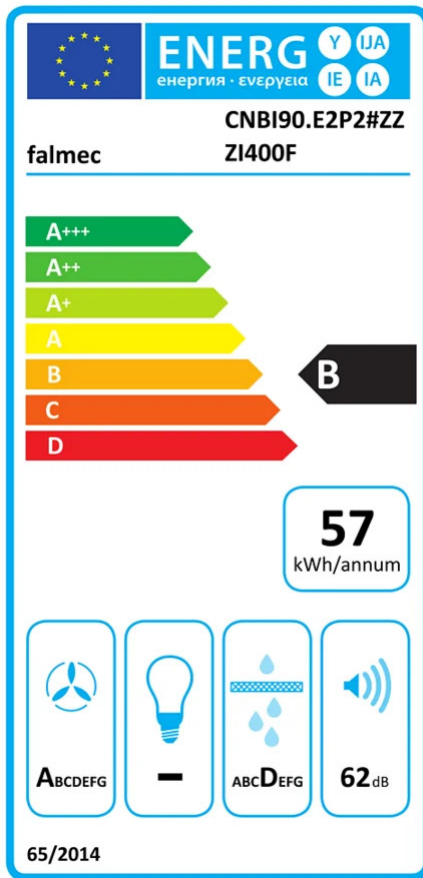

PF		
S	Falmec Lab	
M	Motor de acoperis 950 m3/h	
AEC	57.30	kWh/a
EEC	B	
FDE	28.10	
FDEC	A	
LE	0.00	
LEC		
GFE	65.1	
GFEC	D	
Qmin	365	m ³ /h
Qmax	600	m ³ /h
Qboost	695	m ³ /h
SPEmin	48	dBa
SPEmax	62	dBa
SPEboost	66	dBa
PO		
PS	0.48	W

PI		
F	1.00	
EEL	543.00	
Qbep	384	m ³ /h
Pbep	414	Pa
Qboost	695	m ³ /h
Wbep	157	W

MOTOR SUBȚIRE 800 M3/H

PF		
S	Motor subțire 800 m3/h	
M	Motor subțire 800 m3/h	
AEC	45.4	kWh/a
EEC	B	
FDE	24.2	
FDEC	B	
LE	0	
LEC	0	
GFE	65.1	
GFEC	D	
Qmin	245	m ³ /h
Qmax	470	m ³ /h
Qboost	540	m ³ /h
SPEmin	52	dBa
SPEmax	63	dBa
SPEboost	66	dBa
PO	0	W
PS	0.48	W
PI		
F	1.1	
EEL	58.6	
Qbep	332	m ³ /h
Pbep	297	Pa
Qboost	540	m ³ /h
Wbep	113	W
WL	0	W
Emiddle	0	lux
Lwa-SPEmax		dBa

PF_Scheda prodotto conforme a 65/2014 S_Supplier name / M_Model identification / AEC_Annual Energy Consumption (AEC hood) / EEC_Energy Efficiency class / FDE_Fluid Dynamic Efficiency (FDE hood) / FDEC_Fluid Dynamic Efficiency class / LE_Lighting Efficiency (LE hood) / LEC_Lighting Efficiency class / GFE_Grease Filtering Efficiency / GFEC_Grease Filtering Efficiency class / Qmin_Air flow (in m³/h) at min speed in normal use / Qmax_Air flow (in m³/h) at max speed in normal use / Qboost_Air flow (in m³/h) at intensive or boost setting (max air-flow) / SPEmin_Airborne acoustical A-weighted sound power emissions at min speed in normal use / SPEmax_Airborne acoustical A-weighted sound power emissions at max speed in normal use / SPEboost_Airborne acoustical A-weighted sound power emissions (in dB) at intensive or boost setting / P0_Power consumption in off mode (Po) / Ps_Power consumption in stand by mode (Ps).

PI_Additional information according to 66/2014 Calculation methods: EN 61591:2020 F_Time increase factor / EEL_Energy Efficiency Index / Qbep_Measured air flow rate at best efficiency point / Pbep_Measured air pressure at best efficiency point / Qboost_Maximum air flow / Wbep_Measured electric power input at best efficiency point / WL_Nominal power of the lighting system / Emiddle_Average illumination of the lighting system on the cooking surface / Lwa=SPEmax_Sound pressure level at the highest speed.