

Versiune	Blat 90 cm - Negru
Design	Falmecc Lab Design
	Scotch brite stainless steel (AISI 304) Versiune cu panou personalizabil Aspirație perimetrală Cadru din oțel AISI 304
Control	Telecomandă (opțional) Dialogue system cu mod automat Panou cu buton tactil
Modul	
Iluminat	Bandă LED Strip led (4000K)
Filters	Filtru superior, detașabil și lavabil Filtru combinat Carbon.Zeo, regenerabil (opțional)
Motor	Motor vândut separat
Dimensions	90 cm 0 cm 0 cm
Notes	
Tensiune/frecvență	30 W 220-240V 50-60Hz
Plug	Shuko
Motor	Slim motor 600 m3/h Motor de acoperis 950 m3/h 730 m ³ /h I.E.C.61591 64 dB (A)re1pW I.E.C. 60704-2-13 B
Net Weight	44 kg 37 kg 0.34 m3 L 1070 x H 372 x P 870 mm

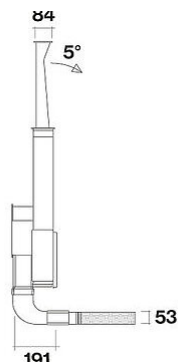

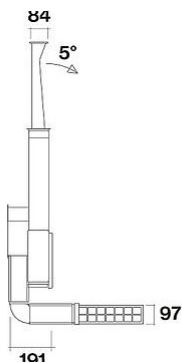
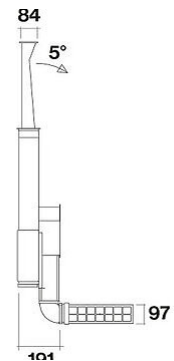
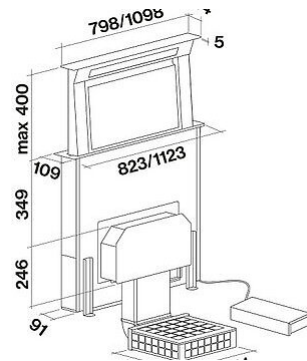
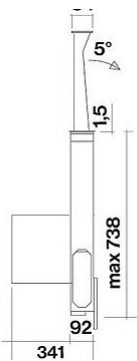
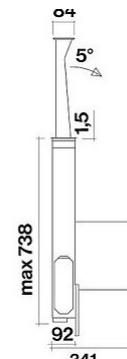
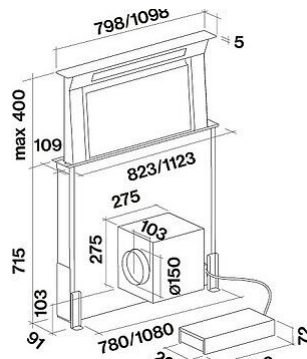
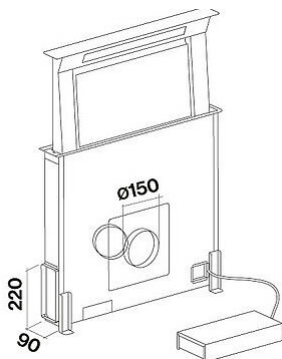

Accesorii optionale

Code	Description
KACL.930	Filtru Carbon.Zeo subbază h100 mm
KACL.931	Filter replacement Carbon.Zeo for vertical outlet and under base kit h100 mm
KACL.951	Underbase Slim filter unit (h60mm)
KACL.952	Filter replacement (underbase Slim filter unit - h60mm)
105080053	Telecomanda
KACL.784#46F	Slim motor 600 m3/h
KACL.798#41F	Motor de acoperis 950 m3/h
KACL.786#41F	Motor de exterior 1000 m3/h
KACL.796#4AF	Motor de exterior 1500 m3/h
KACL.797#4AF	Motor de acoperis 1300 m3/h
KACL.815	Șervețel de protecție pentru suprafețe din oțel inoxidabil (cutie 10 buc.)
KACL.955	Base grid (underbase Slim filter unit - h60mm)

SLIM MOTOR 600 M3/H

CARATTERISTICHE TECNICHE MOTORE

	1	2	3	4
	52	57	64	67
	325	330	550	620
	450	500	400	400
	200	230	240	270
	220x90	220x90	220x90	220x90

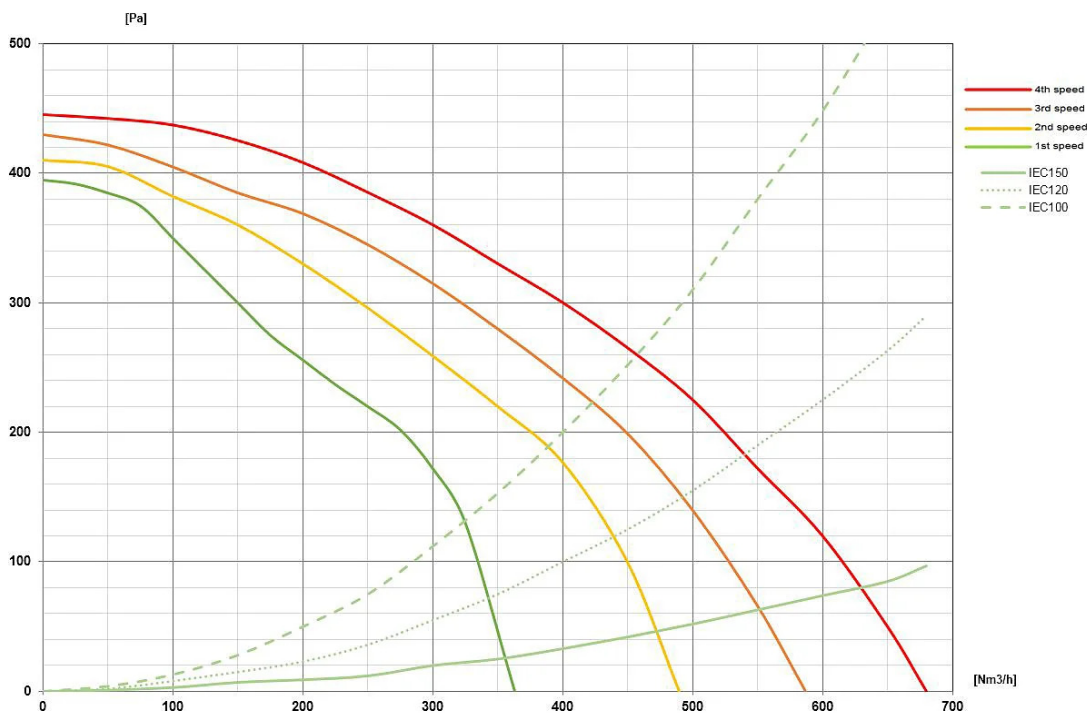

MOTOR DE ACOPERIS 950 M3/H

CARATTERISTICHE TECNICHE MOTORE

	1	2	3	4
	51	59	64	68
	330	480	610	730
	460	520	560	580
	187	210	225	240
	150	150	150	150

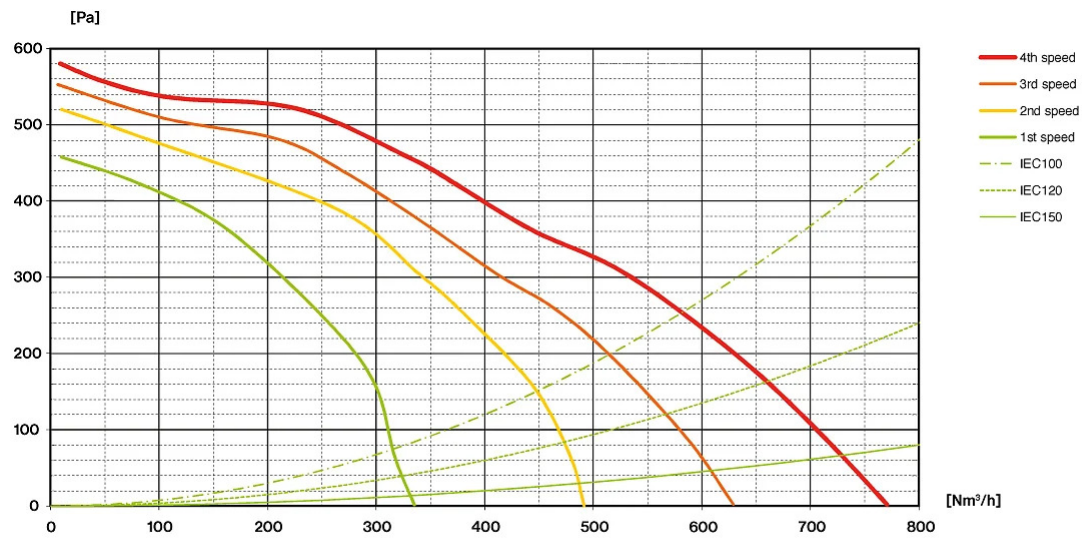

MOTOR DE ACOPERIS 950 M3/H

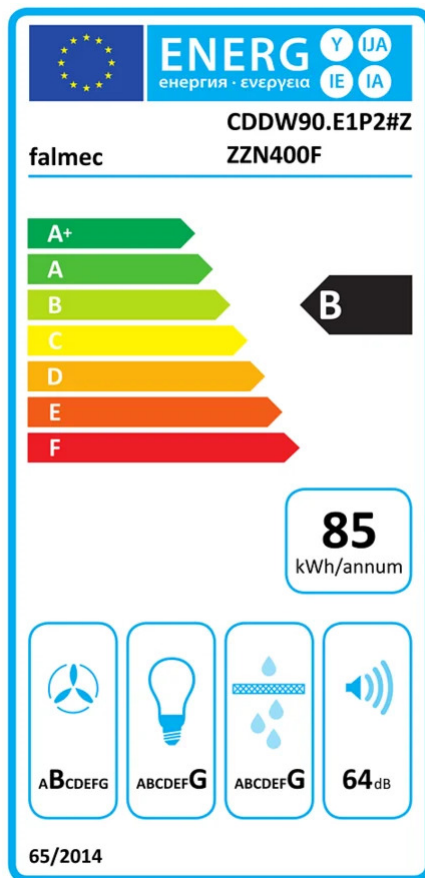

PF		
S	Falmec Lab	
M	Motor de acoperis 950 m3/h	
AEC	84.50	kWh/a
EEC	B	
FDE	24.60	
FDEC	B	
LE	3.00	
LEC	G	
GFE	36	
GFEC	G	
Qmin	330	m ³ /h
Qmax	610	m ³ /h
Qboost	730	m ³ /h
SPEmin	51	dBa
SPEmax	64	dBa
SPEboost	68	dBa
PO	0	W
PS	0.48	W
PI		
F	1.10	
EEL	68.90	
Qbep	369	m ³ /h
Pbep	422	Pa
Qboost	730	m ³ /h
Wbep	176	W
WL	19.00	W
Emiddle	57	lux
Lwa-SPEmax	64	dBa

SLIM MOTOR 600 M3/H

PF		
S	Slim motor 600 m3/h	
M	Slim motor 600 m3/h	
AEC	95.5	kWh/a
EEC	C	
FDE	19.3	
FDEC	C	
LE	3	
LEC	G	
GFE	36	
GFEC	G	
Qmin	325	m ³ /h
Qmax	550	m ³ /h
Qboost	620	m ³ /h
SPEmin	52	dBa
SPEmax	64	dBa
SPEboost	67	dBa
PO	0	W
PS	0.48	W
PI		
F	1.3	
EEL	79.3	
Qbep	440	m ³ /h
Pbep	271	Pa
Qboost	620	m ³ /h
Wbep	172	W
WL	19	W
Emiddle	57	lux
Lwa-SPEmax		dBa

PF_Scheda prodotto conforme a 65/2014 S_Supplier name / M_Model identification / AEC_Annual Energy Consumption (AEC hood) / EEC_Energy Efficiency class / FDE_Fluid Dynamic Efficiency (FDE hood) / FDEC_Fluid Dynamic Efficiency class / LE_Lighting Efficiency (LE hood) / LEC_Lighting Efficiency class / GFE_Grease Filtering Efficiency / GFEC_Grease Filtering Efficiency class / Qmin_Air flow (in m³/h) at min speed in normal use / Qmax_Air flow (in m³/h) at max speed in normal use / Qboost_Air flow (in m³/h) at intensive or boost setting (max air-flow) / SPEmin_Airborne acoustical A-weighted sound power emissions (in dB) at min speed in normal use / SPEmax_Airborne acoustical A-weighted sound power emissions at max speed in normal use / SPEboost_Airborne acoustical A-weighted sound power emissions (in dB) at intensive or boost setting / P0_Power consumption in off mode (Po) / Ps_Power consumption in stand by mode (Ps).

PI_Additional information according to 66/2014 Calculation methods: EN 61591:2020 F_Time increase factor / EEL_Energy Efficiency Index / Qbep_Measured air flow rate at best efficiency point / Pbep_Measured air pressure at best efficiency point / Qboost_Maximum air flow / Wbep_Measured electric power input at best efficiency point / WL_Nominal power of the lighting system / Emiddle_Average illumination of the lighting system on the cooking surface / Lwa=SPEmax_Sound pressure level at the highest speed.